



111 Powdermill Road, Maynard, Mass.

SERVICE BULLETIN

FOR

MODEL 370-B FM STEREO MULTIPLEX TUNER

SPECIFICATIONS

(These are minimum - all H. H. Scott Model 370 tuners must meet or exceed these figures).

Usable Sensitivity (IHFM) (For less than 3% total noise, distortion, hum -30 db.)	3.5 microvolts
Signal to Noise Ratio	60 db. below 100% modulation
Total Harmonic Distortion	1.0%
Frequency Deviation	0.02%
Frequency Response	30 to 15,000 cps ±2 db.
Capture Ratio	6.0 db.
Selectivity	35 db.
Spurious Response Rejection	80 db.
I.M. Distortion (CCIF method)	0.3%
Hum	60 db. below 1 volt
AM Suppression	55 db.
Audio Output (100% modulation)	.8 to 1.2 volts
Tuning Range	87 to 109 mc.
Accuracy of calibration	0.5%
Output Impedance	20,000 ohms
Minimum Recommended Load Resistance	100,000 ohms
Maximum Recommended Cable Capacitance	500 mmfds
Maximum Recommended Length of Output Cable	25 feet
Range of Line Voltage and Frequency	105-125 volt/50-60 cps.
Power Consumption -- AC only -- <u>DO NOT OPERATE</u> <u>WITH DIRECT CURRENT</u>	43 watts

GENERAL SERVICE NOTES

Service, other than replacement of either pilot lights or vacuum tubes is usually not required. If the tuner is not operating properly, all external connections should be checked to make sure that the difficulty is in the tuner. Generally, it is advisable to replace the tuner with a tape recorder or similar device to check out the amplifier performance. The vacuum tubes should be checked by replacing them with new ones, one by one. The tubes should be tight in their sockets and provided with shields where applicable. Tube defects frequently do not show up in a tube tester. Only operation in the tuner will insure the proper working of a vacuum tube. In replacing tubes, if possible, use exact replacement tubes, available from H. H. Scott or any authorized warranty service station. Other tubes will work, but only exact replacement tubes can give the full performance that the tuner is capable of.

The pilot light may be simply replaced by the following procedure:

1. First, set the tuning dial so that the heavy white lines line up with the pointers on the dial and the logging scale is towards the top of the panel. In this position, the tuning condensers are closed.

2. Unscrew and remove the tuning knob and dial. This will permit access to the pilot light which is a VPL-12 bulb.

After the bulb has been replaced, use the following procedure:

1. Close the condenser plates by rotating the condenser to the extreme counter-clockwise position.
2. Replace the dial, lining up the heavy white lines of the dial with the pointers and keeping the logging scale toward the top of the front panel.
3. Replace the tuning knob.

#### ALIGNMENT INSTRUCTIONS FOR FM SECTION

Note: No attempt should be made to align the tuner or repair it unless the person so doing has had extensive experience in tuner alignment and repair procedures and has the necessary laboratory equipment. Without proper experience or equipment, the repairman may seriously damage the tuner.

1. Equipment required: VTVM (AC), FM Signal Generator (must be Measurements 210AB or equivalent), Oscilloscope, 400 cps null, and insulated alignment tools.
2. Equipment set-up: Connect signal generator directly to the 300 ohm antenna input of the tuner using a matching impedance network if necessary. The Channel A audio output of the 370 then feeds into the 400 cps null and from the null to the oscilloscope and VTVM in parallel. If no null is available (a schematic for making one of these very simple and useful devices is available from the Engineering Dept.) the tuner can still be serviced. However, it will not be possible to measure the tuner's "Usable Sensitivity" as per IHFM standards, or align the detector.
3. Allow tuner and test equipment to warm up fully before beginning alignment. Adjust line voltage for 117 volts. Remove bottom cover of tuner. Always tune primary and secondary of I.F. transformers at the same time, using one alignment tool in each hand. Set 370 Selector Switch to Mono.
4. Set generator and tuner for 92 mc. Generator should be modulating a 400 cps signal at 75 kc deviation. Adjust output of generator so that a barely adequate sine wave appears on the scope (on the order of 5 to 10 microvolts). The null filter should be switched out of the setup, so the tuner is feeding directly to the VTVM and scope. Peak the IF's and the primary of the ratio detector (the bottom slug) for maximum reading on the VTVM.
5. Increase generator output to 1000 microvolts and switch the 400 cps null into the circuit. Tune ratio detector secondary (top slug) for minimum reading on the VTVM.
6. Return generator output back down to 5 to 10 microvolts. Adjust antenna coil (under chassis) for maximum output. Tune generator and tuner to 106 mc. with same output and deviation, and adjust antenna trimmers (on top - FM ANT.) for maximum output. Repeat this operation until best results are obtained.
7. If calibration is off, repeat "6" except adjust oscillator coils (under chassis) for correct tracking at 92 mc. and oscillator trimmer (FM OSC - on top) for correct tracking at 106 mc.

#### MISCELLANEOUS SERVICE PROCEDURES AND TESTS - (Qualified technicians only)

Note: Replace bottom plate before testing.

1. Test for IHFM Usable Sensitivity measurements: Use 117 volt regulated line, set generator and tuner at 92 mc, with 10 microvolt input. Take a reference reading on the db. scale and check for 38 db. or more reduction in output with 400 cycle null filter switched in to setup. Repeat at 106 mc. If specification is not met, tuner should be realigned and tubes checked. It is very important that the null filter be carefully adjusted so that it is at exactly the same frequency as the 400 cps modulation being fed in. Otherwise, it will be impossible to obtain stated sensi-

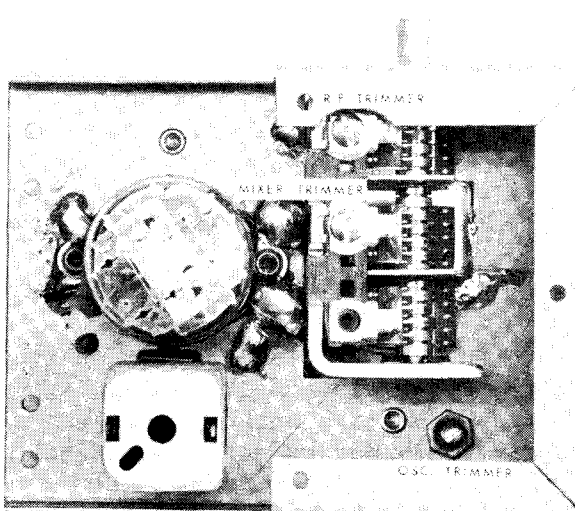
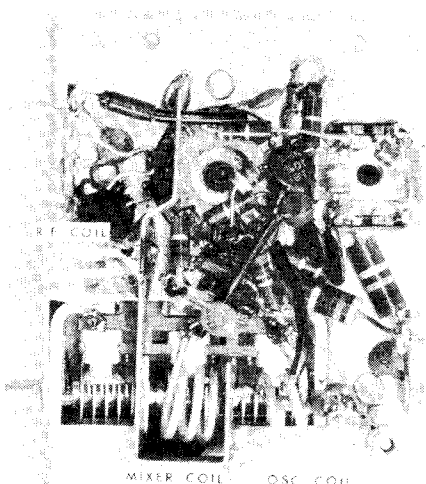

vity figure. Note that 10 microvolt output of generator is equivalent to less than 5 microvolt on tuner input due to drop through the matching impedance network.

2. Audio output: With 1000 microvolt input, 75 kc deviation, maximum output should be 1.5 volts.
3. Automatic Gain Control: The maximum permissible difference in output between an input of 10 microvolts and 1000 microvolts is 8 db.
4. F.M. Hum: At 100 mc., 1000 microvolts input, 400 cycle modulation, take a reference reading and remove modulation. A 60 db drop should be noted.
5. A.C. Hum: With no modulation and level control at minimum, adjust hum pot for minimum hum. Should not exceed .003 volts.
6. Oscillation Check: Check entire FM band for oscillation, with and without antenna, at 105 and 130 volt line.

#### PRELIMINARY MULTIPLEX TESTS

Use same equipment described above, plus a good Audio Oscillator.

1. Connect the audio oscillator to the test point input on the multiplex section. Adjust the output of the oscillator for 0.25 volts. Set the 370 selector to mono.
2. Measure the output of the tuner. It should be 1 to 2 volts with selector switch in either mono or stereo.
3. Disable the multiplex section oscillator by shorting pins #9 and 11 of 6AG11 (V501) to each other. With the audio oscillator at 400 cps take a reference reading. It should be down maximum of 2 db at 20 cps., 2-4 db at 2 KC, 7-9 db at 5 KC, 12-14 db at 10 KC. Continue to 15 KC -- 15-18 db drop, a minimum of 21 db at 20 KC, and minimum of 44 db at 40 KC on both channels.
4. Turn 370 selector switch to Stereo. Set oscillator at 67 KC, 0.25 volts output. Adjust L-502 for minimum output from either Channel A or B. The null is quite broad. If necessary, increase output of audio oscillator for better null.

#### STEREO MULTIPLEX SEPARATION TESTS AND ADJUSTMENTS

Equipment needed: In addition to all the equipment mentioned before you will need a Hewlett-Packard 200CD Audio Oscillator or equivalent (with balanced output to ground -- oscillator with unbalanced outputs cannot be used), and the H. H. Scott Model 830 FM multiplex stereo generator.

Equipment set-up: Use the same arrangement described with the tuner alignment procedure, plus: Connect the Audio Oscillator to the 830 (as described in the 830 Instruction Manual) and the 830 to the FM generator. Set the FM generator for External Modulation.

1. Set audio oscillator to 400 cps. and 830 for left channel (Channel A) signal only. IMPORTANT: The 830 MUST be carefully adjusted for input signal and output phase as described in the 830 Instruction Manual. The output phase must be monitored with a scope to check for variances. If the phase is off even slightly, your alignment will cause the tuner to have poor separation when tuned to station.
2. Set all controls on the 370 for stereo. Tune the 370 to the point on the dial where you are transmitting your Channel A signal. Make sure you pick a point on the dial that does not coincide with a local FM station.
3. Attach scope probe to junction of diodes and 220K resistor (T-501), short pin #9 and #11 at selector switch together. Turn selector switch to monitor position. Peak L-501 and T-501 for maximum output as indicated on scope. Remove short from Pin #9 and #11. Turn selector switch to Stereo.

4. With the audio output of the right channel connected to the horizontal input of the scope, switch the horizontal input of the scope to the Ext. position. Connect the scope probe to the A.C. scale of a VTVM. Short the primary of T-501 and adjust T-502 for zero beat as indicated on the scope.
5. Remove the short and note that the signal locks in.
6. Install the bottom cover and with the signal source still connected to the 370 antenna terminals, tune for maximum AGC left channel signal. Take reference reading and switch to right channel. With the separation pot. at maximum (counter-clockwise) position, adjust L-501 and T-501 for maximum separation. Then readjust separation pot. for best separation. A minimum of 30 db is required.
7. Tune the 370 to the right channel signal and again note 30 db separation.
8. It is important to realize that maximum meter reading will not exactly coincide with maximum audio output (within 2 db) and maximum separation. However, it comes extremely close to both and does give a good combination of separation, output, and low distortion.

#### EMERGENCY MULTIPLEX SEPARATION ADJUSTMENTS WITHOUT SPECIAL TEST EQUIPMENT

The following adjustments should only be attempted if it is impossible to get the proper multiplex test equipment and it is obvious that stereo separation is not satisfactory. The only way to be sure the tuner is at fault is to substitute another tuner, known to be working properly. (Very often a tuner will not appear to have good separation when actually the station or the program material is at fault).

The primary requirement is to have a local FM station broadcasting multiplex stereo with spoken announcements on one channel only. Most multiplex stations do provide this service at certain times of the day. Call the station and check. If they are among the few that are not broadcasting speech on one channel only, you might point out how valuable it would be to service people in their area if they did.

1. Assume the FM multiplex station is transmitting commercials on the right channel only (reverse everything if it is left only).
2. Connect an audio cable from Channel A output to an amplifier and a speaker.
3. Tune in the station carefully, using the tuning meter. Set Selector to Stereo.
4. When the announcer begins to talk, he should be barely audible in Channel A or the left channel signal. Carefully retune till you find the point where the sound is faintest (you should be quite close to the maximum meter reading position).
5. Carefully rotate the "Sep" pot on the multiplex adaptor until the voice is at its faintest. Keep the volume up on the amplifier.
6. If this does not provide sufficient improvement, take the detector alignment tool and insert it into the top of L-501. Rotate slowly for the best separation point. Then readjust the "Sep" pot.
7. If this does not help, the difficulty may be with the station or with some other part of the system. For more information, write to:



Technical Services Dept.  
H. H. Scott, Inc.  
111 Powder Mill Road  
Maynard, Massachusetts

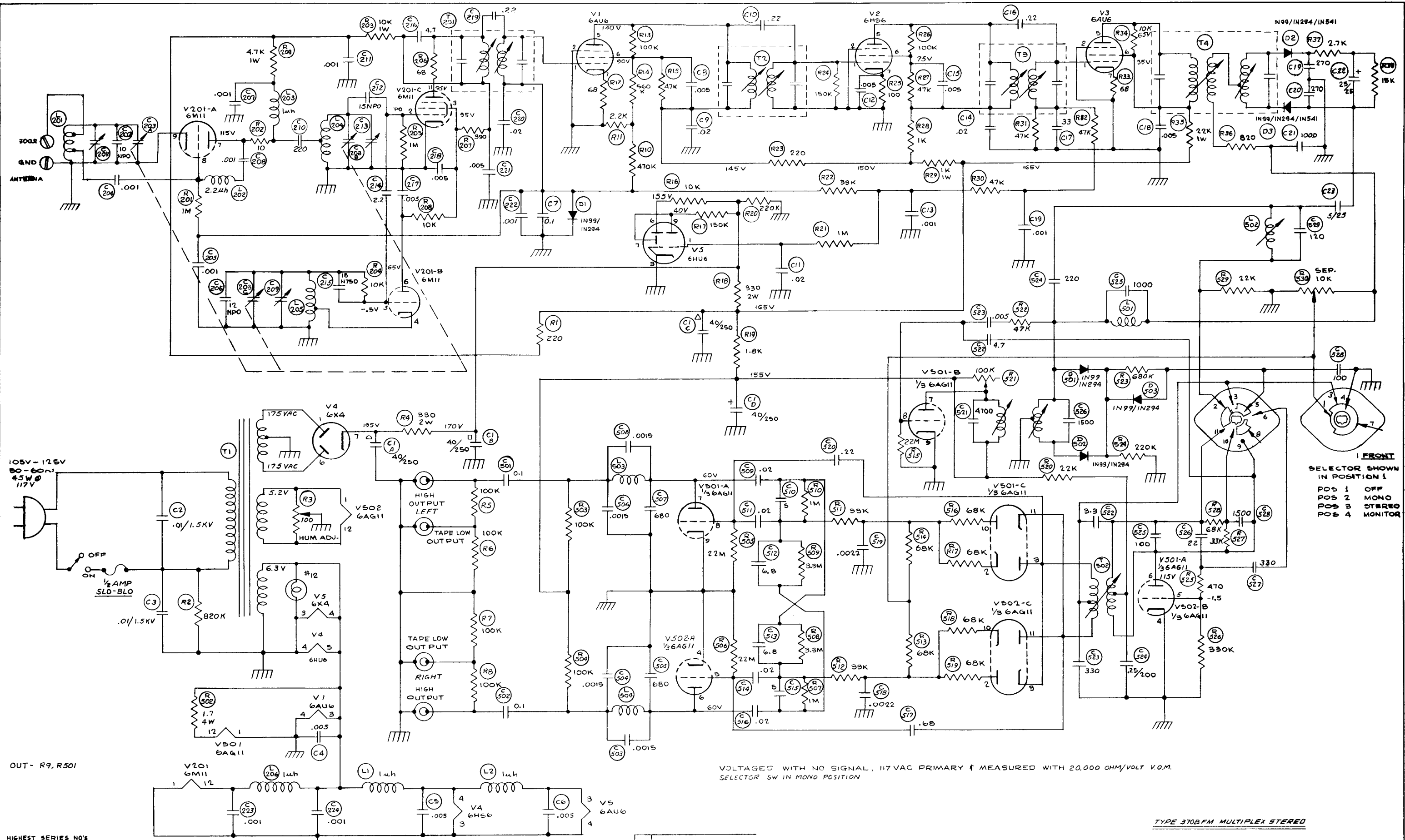

FRONT  
 SELECTOR SHOWN  
 IN POSITION 1  
 POS 1 OFF  
 POS 2 MONO  
 POS 3 STEREO  
 POS 4 MONITOR

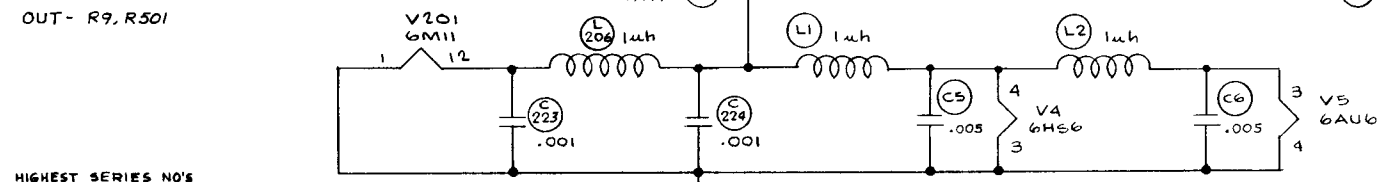

VOLTAGES WITH NO SIGNAL, 117VAC PRIMARY & MEASURED WITH 20,000 OHM/VOLT V.O.M.  
 SELECTOR SW IN MONO POSITION

HIGHEST SERIES NO'S

C224	C23	C535
R208	R38	R530
T201	T4	T501
L206	L2	L504
	D3	D503

UNLESS OTHERWISE SPECIFIED  
 RESISTANCE IS IN OHMS  
 CAPACITANCE IS IN pF  
 SWITCH(S) SHOWN IN MAX. CCW POSITION  
 SWITCH TERMINAL NUMBERS FOR REF. ONLY

SCALE: ~	CIRCUIT DIAGRAM	11-4-62
H. H. SCOTT, INC. MAYNARD, MASS., U.S.A.		
DR. R. SMITH	ENG. <i>Swit</i>	DWG. NO. D-370B-C1
CH.	PROD.	SUB. 0

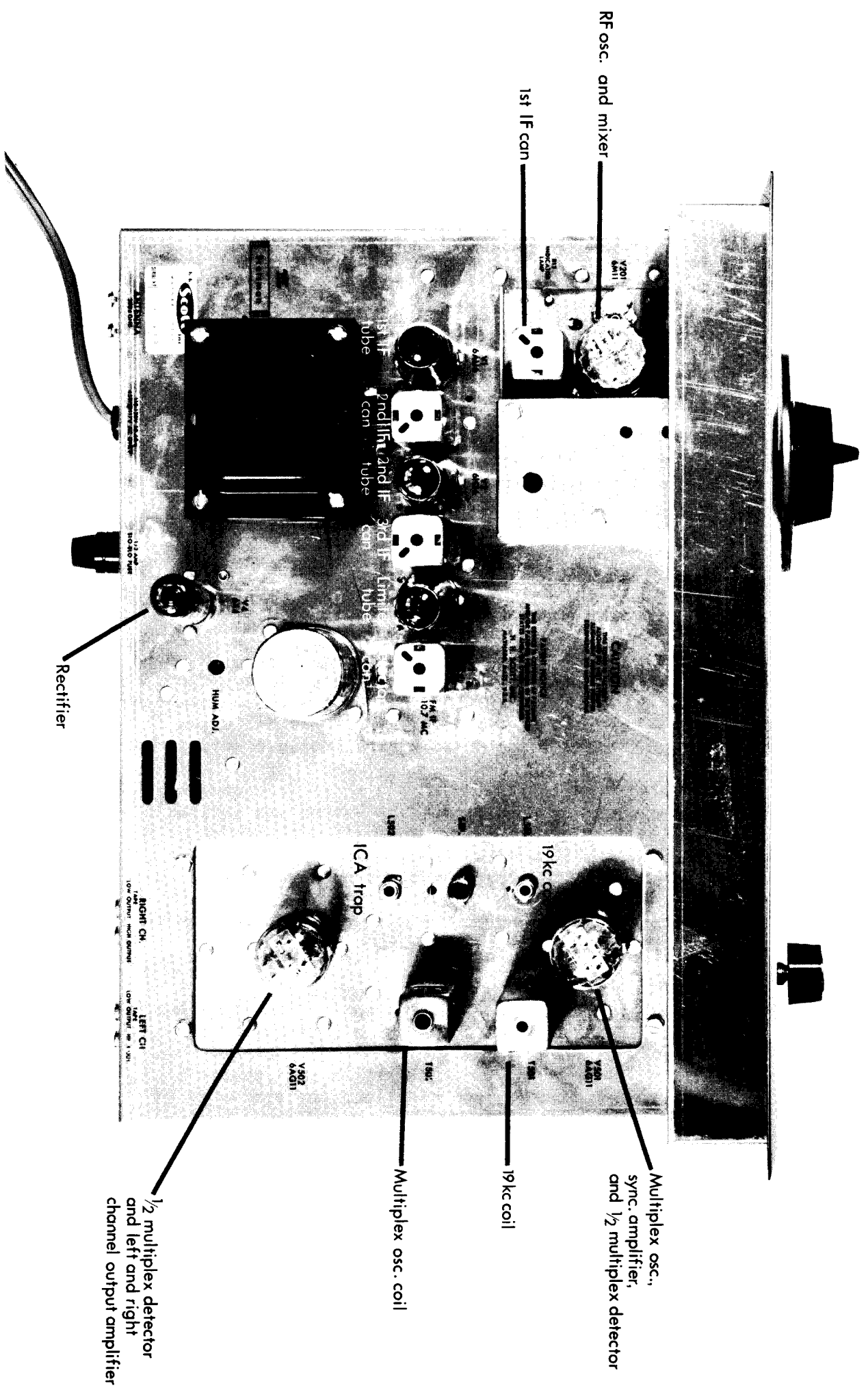

RF osc. and mixer

1st IF can

2nd IF can

3rd IF can

Rectifier

Multiplex osc.,  
sync. amplifier,  
and 1/2 multiplex detector

19 kc coil

Multiplex osc. coil

1/2 multiplex detector  
and left and right  
channel output amplifier